



 AUDIO

 VIDEO

 SECURITY

# 1x8 HDMI Splitter / Extender

**User Manual**

# Thank you for purchasing this product

For optimum performance and safety, please read these instructions carefully before connecting, operating or adjusting this product. Please keep this manual for future reference.

## Surge protection device recommended

This product contains sensitive electrical components that may be damaged by electrical spikes, surges, electric shock, lightning strikes, etc. Use of surge protection systems is highly recommended in order to protect and extend the service life of your equipment.

## Table of Contents

<b>1. Introduction</b> .....	<b>2</b>
<b>2. Features</b> .....	<b>2</b>
<b>3. Package Contents</b> .....	<b>2</b>
<b>4. Specifications</b> .....	<b>3</b>
<b>5. Operation Controls and Functions</b> .....	<b>3</b>
<b>6. Connection Diagram</b> .....	<b>9</b>

# 1. Introduction

The Splitter is a product for splitting and extending your HDMI signal over long distances to a compatible display. It is designed to convert the HDMI signal and transmit by Internet cable. The splitter supports resolutions up to 1080p@60Hz, and supports smart EDID management.

## 2. Features

- ✧ Compliant with HDMI1.3, HDCP 1.2 and DVI 1.0.
- ✧ Full HD support: 1080p@60Hz@24 bit/pixels.
- ✧ Supports LPCM 7.1CH, Dolby True HD, and DTS-HD Master Audio.
- ✧ Operates for TMDS clock frequencies up to 148.5MHz.
- ✧ Support Power over cable function.
- ✧ Use single UTP LAN cable (CAT5E/6) to substitute HDMI cable to achieve long distances transmission.
- ✧ UTP cable termination follows the standard of IEEE-568B.
- ✧ Supports EDID control via EDID selector.

## 3.Package Contents

- ✧ HDMI Splitter ----- 1pcs
- ✧ Receiver ----- 8pcs
- ✧ 12V2.5A DC Power Supply adapter ----- 1pcs
- ✧ Wideband IR Tx cable ----- 1pcs
- ✧ Wideband IR Rx cable ----- 8pcs
- ✧ Operation Manual ----- 1pcs
- ✧ Mounting ears ----- 2pcs

## 4. Specifications

Technical	
Maximum Pixel Clock	165 MHz
Supports video resolutions up to	1080p@60Hz
ESD Protection	Human body model — ±8kV (air-gap discharge) & ±4kV (contact discharge)
Power Supply	DC 12V 2.5A
HDMI Splitter	
Input Ports	1xHDMI, 1xMini USB
Output Ports	1xHDMI, 8xRJ45, 1xIR out
Receiver	
Input Ports	1xRJ45, 1x IR in
Output Ports	1xHDMI
Mechanical	
Dimensions (mm)	295(W) X 83 (D) X 17 (H)
Weight	HDMI Splitter: 720g Receiver: 8 x 131g
Operating Temperature	0°C ~ 40°C / 32°F ~ 104°F
Storage Temperature	-20°C ~ 60°C / -4°F ~ 140°F
Relative Humidity	20~90% RH (Non-condensing)
Power Consumption (Max)	15W

## 5. Operation Controls and Functions

### 5.1 Top Panel

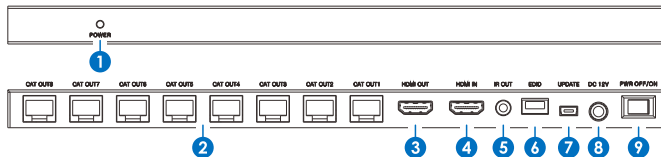

- 1 **POWER LED:** This red LED will illuminate when the device is connected with power supply.
- 2 **CAT OUT1-OUT8:** Eight RJ45 ports provide signal output.
- 3 **HDMI OUT:** Local HDMI loop output port.
- 4 **HDMI IN:** HDMI Input port. Connect source with HDMI cable.
- 5 **IR OUT:** Connect the IR Blaster cable included in the package for IR signal transmission. Place the IR blaster in direct line-of-sight of the equipment to be controlled.
- 6 **EDID :** Select output signal format via EDID Selector.  
 ※See the description 1
- 7 **UPDATE:** System software update.
- 8 **DC12V:** Plug the 12V2.5A DC power supply into the unit.
- 9 **POWER OFF/ON:** Power ON\OFF Switch.

## 5.2 Receiver

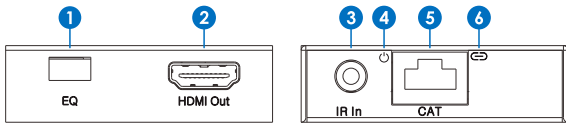

- 1 **EQ switcher:** HDMI Receiver equalizer switcher.  
 ※See the description 2
- 2 **HDMI out:** This slot is to connect the HDMI input port of your display such as an HDTV.
- 3 **IR In:** Connect to the IR Receiver for IR signal reception. Ensure that remote being used is within the direct line-of-sight of the IR receiver.

- 4 **Power LED:** This LED will illuminate when the device is connected with power supply.
- 5 **CAT:** Connect the CAT input of the receiver with the CAT output of the transmitter with CAT5E/6 cable.
- 6 **Lock LED:** This LED will illuminate when the HDMI signal from the transmitter is stable.

## ✘ See the description 1

### EDID Control

Under normal circumstances, a source device (digital and analog) will require information about a connected device/display to assess what resolutions and features are available. The source can then cater its output to send only resolutions and features that are compatible with the attached device/display. This information is called EDID (Extended Display Information Data) and a source device can only accept and read one EDID from a connected device/display. Likewise, the source could only output one resolution to connected device/display.

The EDID switch allows for EDID learning or to pre-set an EDID to encourage a “handshake” between the display and source.

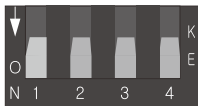

### Manual EDID Learning Mode













When you switch to any number of “0-8”, the Transmitter will set a fixed EDID to the source. The detail EDID description, please refer to the EDID table.



### Auto EDID Learning Mode

When you switch to “9”, the Transmitter will copy the HDMI LOOP OUT port display EDID to source.

**Attention: Please confirm the extender is work normally, when you want to modify the new EDID to source, toggle the EDID switcher to the corresponding number first, then plug the Transmitter power again. The extender will send the new EDID to source.**

**EDID TABLE:**



Position	EDID Description
 0	1080p, 2CH AUDIO
 1	1080p, DOLBY/DTS 5.1
 2	1080p, HD AUDIO
 3	1080i, 2CH AUDIO
 4	1080i, DOLBY/DTS 5.1
 5	1080i, HD AUDIO
 6	3D, 1080p, 2CH AUDIO
 7	3D, 1080p, DOLBY/DTS 5.1
 8	3D, 1080p, HD AUDIO
 9	Copy EDID from the Transmitter HDMI loop out
 A	1080p, 2CH AUDIO
 B	1080p, 2CH AUDIO
 C	1080i, 2CH AUDIO

 D	1080i, 2CH AUDIO
 E	1080i, 2CH AUDIO
 F	1080i, 2CH AUDIO

## ※See the description 2

### RX Equalizer distance adjust

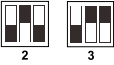
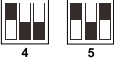
If you find flickering or blinking image on the display, adjust the EQ switch to improve the cable skew. MAX stands for the strongest HDMI signal level for the longest possible transmission length while MIN stands for the weakest HDMI signal level for short transmission length. Adjust the signal level from MIN to MAX until ideal video quality displayed.

Recommended EQ setting	
Position	Cable Length
 0      1	under 15m (49.5ft)
 2      3	15-30m (49.5 ft - 99ft)
 4      5	30-40m (99ft - 132ft)
 6      7	40-50m(132ft – 164ft)



## Wideband IR(30KHz--60KHz) introduction



## IR Cable Pin Assignment

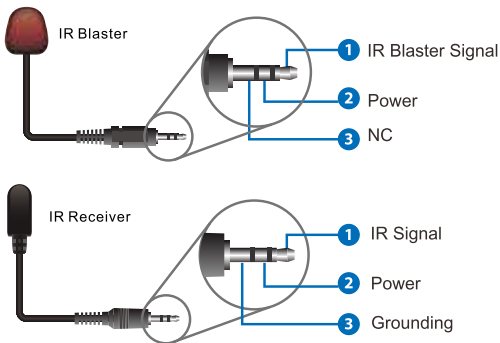

Control local device (Blu-ray player or DVD player, etc) from remote: The IR Receiver is connected to the receiver IR in port. The CAT output connector on the HDMI Splitter is connected via CAT6 cable to an HDMI receiver. The IR Transmitter is connected to the HDMI Splitter IR OUT port. IR remote can be used to control local source device from remote.

## 6.Connection Diagram

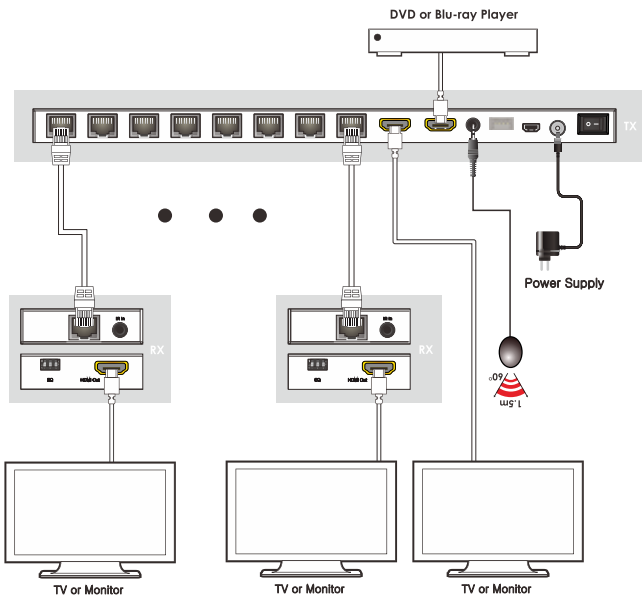

- ✧ Connect a source such as a Blu-Ray Player, game console, A/V Receiver, Cable or Satellite Receiver, etc. to the HDMI input on the Transmitting unit.
- ✧ Connect a display such as an` HDTV or HD Projector to the HDMI output on the Receiving unit.
- ✧ Connect a single Cat5e/6 up to 164ft/50m to the output of the Transmitting unit, and the other end to the input of the Receiving unit.
- ✧ Connect the DC 12V Locking power supply to the power receptacle on the splitter.
- ✧ Connect the power supply to an available electrical outlet.