

Russound®

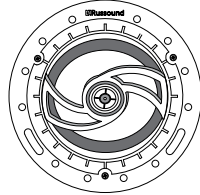

RSA-615

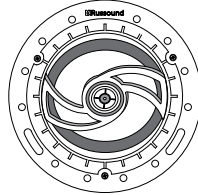

RSA-635

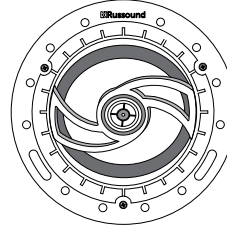

RSA-835

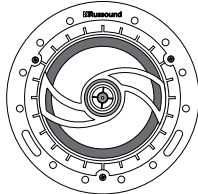

RSF-610

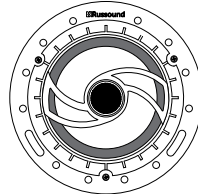

RSF-620

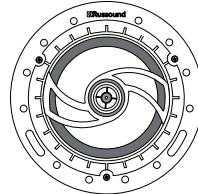

RSF-635

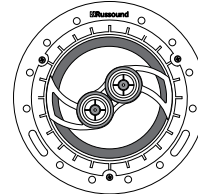

RSF-610T

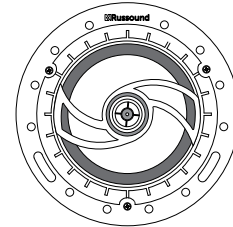

RSF-820

Acclaim™ Speakers With Magnetic Edgeless Grilles

Installation Manual

TABLE OF CONTENTS

Preparation/Wiring Info	3
Preparation/Speaker Placement.....	4-5
Preparation for Installation	6-7
Installation	8
Tests and Adjustments	9
Troubleshooting Guide	9
Technical Specifications.....	10
Troubleshooting Guide & Warranty	11

INTRODUCTION

Thank you for selecting the Russound Acclaim In-ceiling and In-wall Speakers. Like all Russound speakers, they combine acoustic technology with durability and will provide years of musical enjoyment. The speaker line provides solutions for everything from background music to dedicated music listening and even home theater installations.

Many of the Acclaim models use Russound's proprietary NeoDrive™ technology with advanced neodymium motor structures that weigh substantially less than traditional speaker components. Russound Acclaim speakers feature high quality drivers, sophisticated crossover networks, and advanced designs to ensure optimum reproduction in your home for whatever your favorite music may be.

Angeled Woofer for Directional Sound - 15°, two-way, in-ceiling

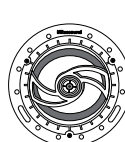

RSA-615



RSA-635

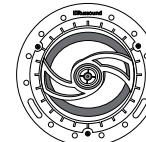

RSA-835

Two-way, in-ceiling, in-wall

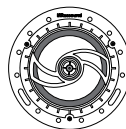

RSF-610

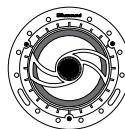

RSF-620

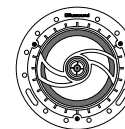

RSF-635

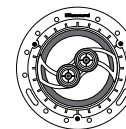

RSF-610T

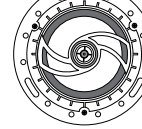

RSF-820

Magnetic Edgeless Grilles

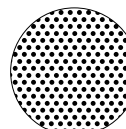

RSG-6R
Round grille.
(included with
the speakers)

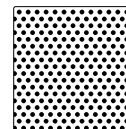

RSG-6S
Square grille,
optional.
(sold separately)

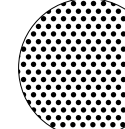

RSG-8R
Round grille.
(included with
the speakers)

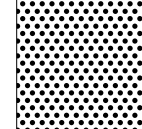

RSG-8S
Square grille,
optional.
(sold separately)

Speaker Wire

What kind to use: We recommend using Russound speaker cable or any 16 to 14 gauge multi-stranded wiring for amplifier-to-speaker connections.

Selecting the proper gauge: Wire is measured in gauges: the bigger the gauge, the smaller the diameter of the wire. The gauge of wire needed is determined by the distance between your amplifier/receiver and the speakers. The longer the wire run, the heavier the gauge needed. Use the following chart as a guide:

<u>Length</u>	<u>Minimum Gauge</u>
0' to 150' (0 to 45m)	16
100' to 200' (30 to 60m)	14

If the conductors are not sheathed in colored jackets, be consistent with usage. The standard colors on the terminals are red Positive (+) and black Negative (-). If the wire has transparent insulation, one conductor will be copper-colored (+) and the other silver-colored (-). If the wire has an opaque insulation, the conductors are differentiated by a series of ribs or grooves, a stripe, or dotted line on one conductor. Use and mark these as the Positive (+) conductor.

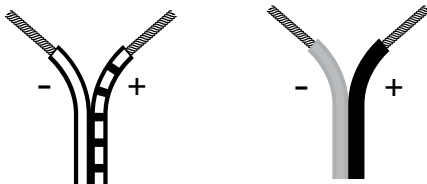

Typical usage of speaker wire conductors

Installation Tips

When installing the speakers, avoid:

- T-bar "drop ceilings" with very thin fiberboard panels which can buzz and vibrate. If needed, reinforce the drop-in panel with wood or particle board.
- Ceilings where there are pipes, heating ducts and especially AC wiring in the general vicinity. Local building codes may dictate the type of wire you need to use. Only wire that is rated for use in walls/ceilings should be used for that purpose.

Speaker Wire Paths

- Avoid running speaker wires close to house electrical wiring for any distance. If you have to run them to the same locations, leave two feet between the wiring. Speaker wires should cross AC lines at a 90° angle.
- The entire path between speakers and amplifier should be clear and unobstructed. Confirm placement for a wall port close to the intended location of the amplifier or receiver.
- Label speaker wires at each end with Left and Right and the room location.

Impedance Matching for Amplifiers and Speakers

Not all amplifiers or receivers can safely operate two sets of speakers at once. If you intend to use more than one pair of speakers at a time it's important to consider both the impedance of the speakers and the capabilities of the amplifier or receiver you're using.

PREPARATION / SPEAKER PLACEMENT

Use and Placement

Determine the intended use and placement of the speakers in the room. If they are going to be your primary listening source in a room, you need to consider some other factors to ensure proper imaging. The term "stereo imaging" refers to a speaker system's ability to project music so that it sounds like the performers are in a three-dimensional space between the speakers.

The Acclaim speaker models RSA-615, RSA-635, and RSA-835 are designed to provide focused dispersion, ensuring that high quality sound fills the chosen listening area.

Models RSF-610, RSF-620, RSF-635, RSF-610T, and RSF-820 are designed to provide uniform dispersion throughout a wider area.

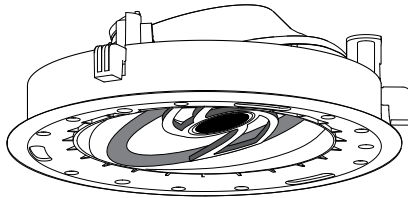

15° - Angled Woofer

Models:
RSA-615
RSA-635
RSA-835

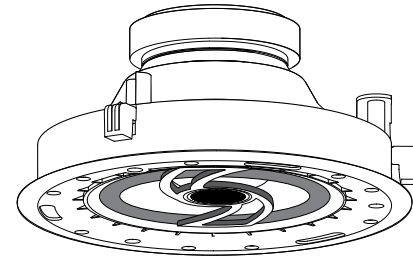

0° - Straight on Woofer

Models:
RSF-610
RSF-620
RSF-635
RSF-610T
RSF-820

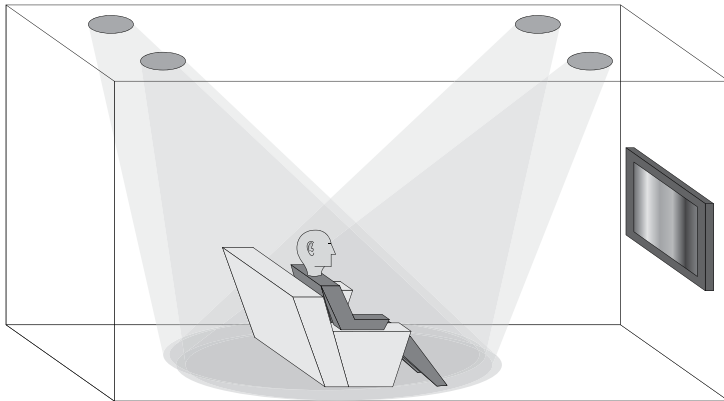

Focused dispersion - using 15° tilt

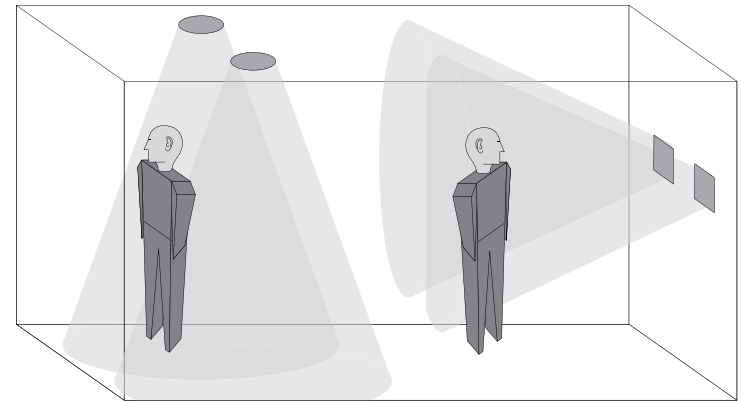

Uniform dispersion - using 0° flat

Speaker Placement in the Room

Bass frequencies are emphasized when ceiling speakers are placed close to a wall or ceiling. Avoid placing one speaker in a corner and another on a long flat surface. The best acoustic performance will result if both speakers are placed in similar positions and face a similar type of surface.

The ceiling surround speakers should be placed directly to the sides or rear of the prime listening position, but be aimed toward the listener. This configuration is also suitable for a TV/movie and music mixed use.

If the prime purpose of the surround system is to listen to music, the ceiling speakers should be aimed at the prime listening position.

Acclaim In-ceiling speakers may be used for rear surround sound channels by placing them just behind the viewers. Refer to the placement diagram.

Refer to the details at right for sample In-ceiling placement options.

- *Good placement for serious listening:* Stereo pair In-ceiling. 6' to 8' (1.8m-2.4m) apart, on the long wall of a rectangular room, centered on the listening area.
- *Best placement for serious listening:* Stereo pair In-ceiling. 6' to 8' (1.8m-2.4m) apart, on the short wall of a rectangular room, centered on the listening area.
- *Good placement for background listening:* Stereo pair behind, above or to the sides of the main listening area. 6' to 8' (1.8m-2.4m) apart, centered on the listening area.
- *Surround sound:* The multiple surround locations can all be made to work as long as the speakers are properly directed. The ceiling speakers should be directed so that the sound is aimed toward the listener.

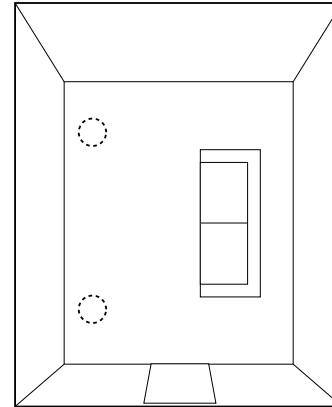

Good Placement
Serious Listening

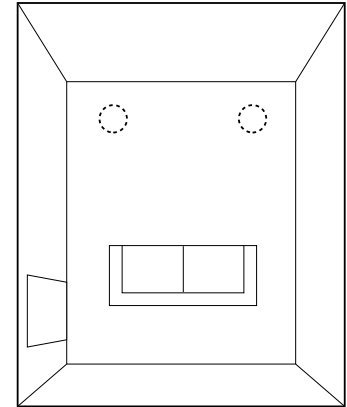

Best Placement
Serious Listening

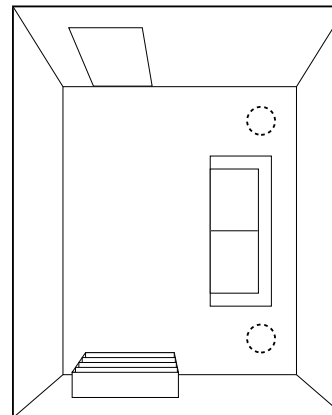

Good Placement
Background Listening

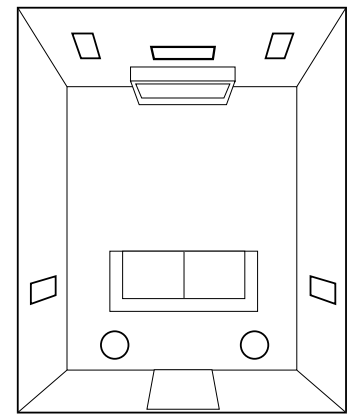

Home Theater
Surround Sound

PREPARATION FOR INSTALLATION

Pre-wire or Pre-construction

Locate all obstructions (AC wiring, plumbing, duct work, studs, and joists). Route the speaker wire to the speaker location avoiding all obstacles.

Russound offers Speaker Rough-In Brackets that can be fastened to the adjacent studs. Once the dry wall is installed, the opening is cut out. There are holes molded into the bracket for speaker wire tie-off to keep the wire from being lost during construction.

In-ceiling bracket Installation

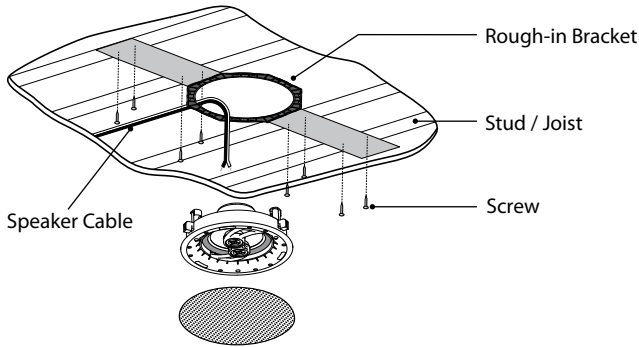

In-wall bracket Installation

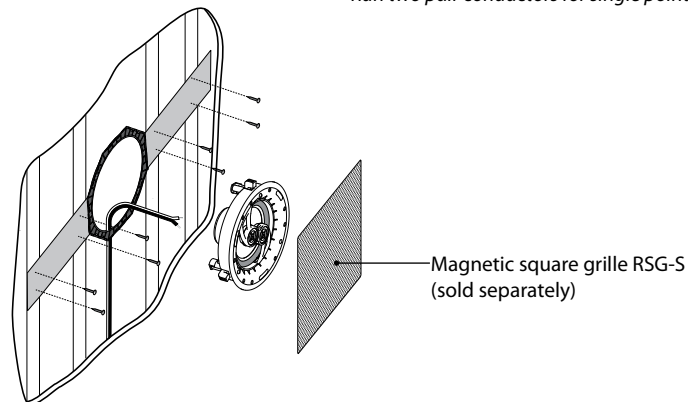

Note:

Run two pair conductors for single point speakers.

Make sure the speaker cutout (hole) doesn't extend further than ¼" (0.6 cm) from the inside of the mounting bracket.

Retrofit Installation

Locate existing pipes, duct work, and AC wiring before cutting any holes in the ceiling.

1. Center the cardboard template between adjacent joists, avoiding all wiring, pipes, duct work, and lightly mark the outline with a pencil. Then use a keyhole/drywall saw or motorized spiral-cut tool to make the opening.
2. Score the outline of the template with a utility knife to prevent chipping. If dealing with lath and plaster or thick paneling, drill 1" (2.5 cm) holes in several places around the pencil outline. Use a fine-toothed keyhole saw or hacksaw blade with slow strokes to saw through and remove the inner surface.

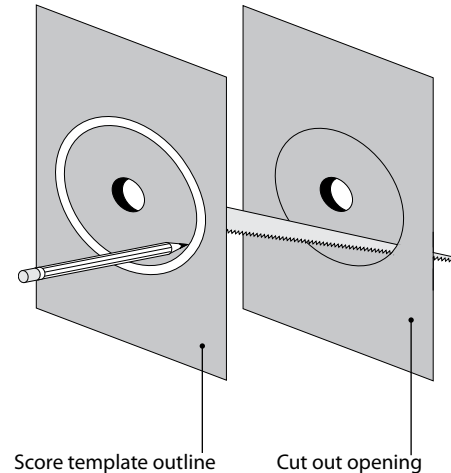

Retrofit Installation

Additional Tips / Considerations

- If possible, run speaker wires after AC wiring is in place so you can separate the wires and avoid induced noise caused by close parallel proximity of the two types of wire.
- Secure speaker wires in place against a stud along vertical runs. Do not pierce the wire insulation. Allow a bit of slack for expansion of building materials.
- Route horizontal wire runs through holes drilled in studs at roughly equal heights.
- The speakers should not be installed until the wallboard is in place. In the meantime, leave several feet of wire coiled up and secured to the back side of the mounting frame. Excess length can be removed during final assembly.
- When installing the drywall, make sure the speaker cutout hole doesn't extend farther than ¼" (0.6 cm) from the inside of the mounting frame.
- Any speaker installed in a ceiling should have a safety wire firmly tied between the back of the speaker assembly and the frame of the building. Use any strong insulated wire and connect it to the speaker frame or baffle, being careful not to let it interfere with the speaker's operation. The other end should be firmly attached to the joist or flooring above using a hook, nail, or other reliable fastener.
- Terminate the wires in an outlet box attached to a stud or retrofit junction box at the exit location. Utilize an outlet plate which has connections for speaker wire terminations.
- After the drywall is secured and finished, install the speakers as described in this manual.

Painting the Speaker Grille

Russound Acclaim Speaker Grilles have a designer white finish that can be painted with ordinary latex paint. Remove the speaker grille from the speaker before painting.

1. Remove the magnetic speaker grille and remove the scrim cloth from the grille and set aside.
2. Paint the grille. Russound recommends diluting the latex paint with water 4:1 or 5:1 proportionally.
3. While the paint is still wet on the grille, and the grille is not attached to the frame, use a gentle burst of compressed air against the outside surface to clear the fine holes in the mesh.
4. After the paint has thoroughly dried, re-attach the scrim cloth, and attach the grille to the frame.

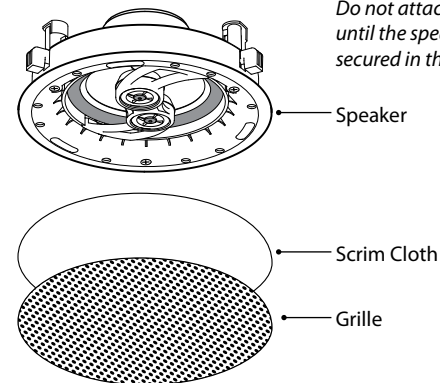

Do not attach the scrim cloth and grille until the speaker has been connected and secured in the ceiling.

Speaker Assembly

INSTALLATION

Installation

1. Connect the speaker wire to the speaker terminals:

- Leave about 2' (60 cm) of wire extending through the ceiling cutout.
- Pull the conductors apart so the last two inches are separated and remove ½" (13 mm) of insulation from the end of each conductor.
- Twist the strands in each conductor into tight spirals.
- Attach the speaker wires to the red and black speaker terminals. Connect the Positive (+) conductor to the Red terminal and the Negative (-) conductor to the Black terminal. Make sure that no stray strands of wire are touching the other conductor or terminal.
- Single point speakers have four terminals; Right(+), (-) and Left(+), (-). Run an extra pair of conductors and observe proper polarity when making connections.

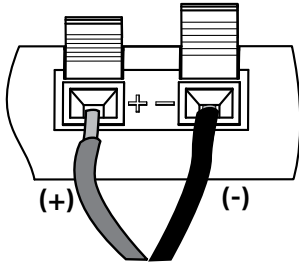

Models:
RSF-610
RSF-620
RSF-610T
RSF-820
RSA-615

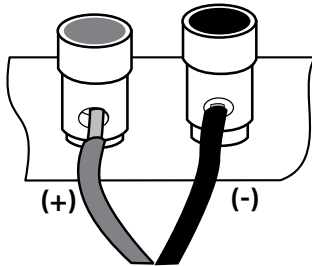

Models:
RSF-635
RSA-635
RSA-835

Insertion of speaker wire on back of speaker baffle

2. Center the speaker in the cutout. Rotate the frame as needed before tightening the screws. Tighten the screws equally until the clamps secure the frame. Do not overtighten.
3. Attach the magnetic grille.

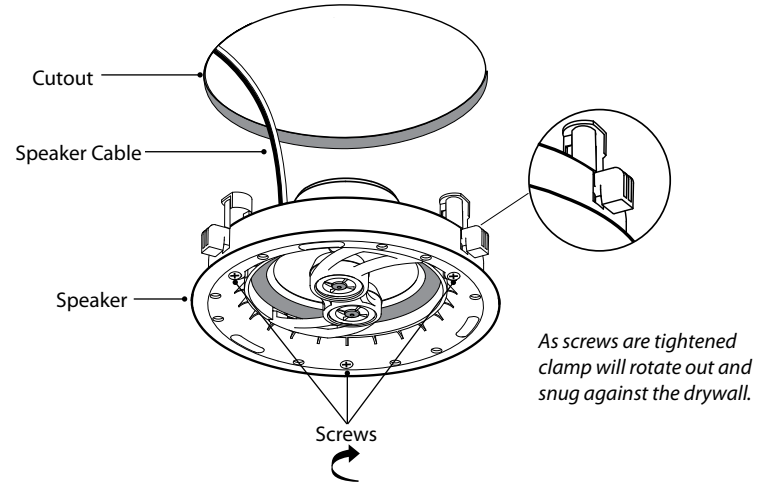

Install Speaker

Listening Test

It's a good idea to test everything at this point.

1. Turn on your stereo system or music source. Make sure that the volume control is turned down and that the balance control is set to center.
2. Gently turn up the volume. You should hear music coming out of your new Russound Speakers! (If you don't, refer to the troubleshooting guide.)
3. Now rotate the stereo's balance control all the way to the left. Sound should only come out of your left speaker. If it comes out of the right speaker, skip to Step 5.
4. Rotate the balance control all the way to the right. Sound should only come out of the right speaker.
5. If sound comes from the right speaker when the stereo's balance control is turned to the left, you'll need to change the connections on the back of the amplifier/receiver. **Note:** Turn off the amplifier. Swap the wires attached to the left and right speaker terminals before turning the amplifier back on.

Tweeter Adjustment

The tweeters pivot and should be aimed toward the intended listener. Before installing the grille, gently press on the outside of the tweeter ring as shown. (Not applicable for the RSF-610T)

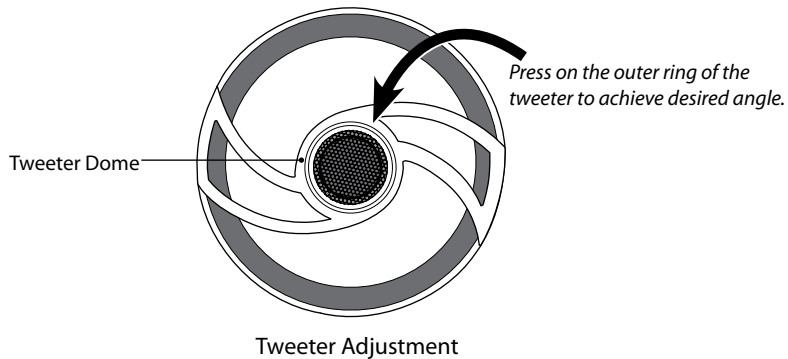

Adjusting the Frequency Response

Several models are equipped with Treble and Dialogue enhancement frequency adjustment switches. Turn the switch to change the settings.

-3 dB: Reduces the loudness of the selected frequency (Treble)

+3 dB: Increases the loudness of the selected frequency (Treble or Dialogue)

+6 dB: Increases the loudness of the selected frequency (Dialogue)

0 dB: Selected frequency remains neutral (recommended start setting)

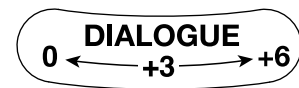

TECHNICAL SPECIFICATIONS

Two-way, in-ceiling, in-wall

Model	Description	Woofers	Tweeter	Recommended Power	Frequency Response	Sensitivity	Nominal Impedance	Magnet Structure	Overall Dimensions	Cut-out Dimensions	Mounting Depth
RSF-610	Performance Series	6.5" (16.51 cm) Polypropylene cone w/NBR surround	0.75" (1.91 cm) Pivoting PEI dome	5 - 80 watts	50Hz - 20kHz	88dB @ 1w/1m	8 ohms	11 oz (0.312 kg)	9.13" dia. (23.19 cm)	8.375" dia. (21.27 cm)	3.49" (8.86 cm)
RSF-620	High Resolution Series	6.5" (16.51 cm) Polypropylene cone w/NBR surround	1" (2.54 cm) Pivoting silk dome	10 - 100 watts	50Hz - 20kHz	90dB @ 1w/1m	8 ohms	11 oz (0.312 kg)	9.13" dia. (23.19 cm)	8.375" dia. (21.27 cm)	3.49" (8.86 cm)
RSF-635	High Resolution Series Shallow Depth	6.5" (16.51 cm) IMPP/mica cone w/NBR surround	0.75" (1.91 cm) Pivoting silk dome	10 - 100 watts	45Hz - 20kHz	88dB @ 1w/1m	8 ohms	Neo Magnet N40	9.13" dia. (23.19 cm)	8.375" dia. (21.27 cm)	2.72" (6.9 cm)
RSF-610T	Single Point Stereo	6.5" (16.51 cm) IMPP/carbon fiber cone w/NBR surround	2 x 0.75" (1.91 cm) silk dome	10 - 120 watts (total)	40Hz - 20kHz	90dB @ 1w/1m	8 ohms	20 oz (0.567 kg)	9.13" dia. (23.19 cm)	8.375" dia. (21.27 cm)	3.69" (9.37 cm)
RSF-820	High Resolution Series	8" (20.32 cm) Polypropylene cone w/NBR surround	0.75" (1.91 cm) Pivoting silk dome	10 - 100 watts	35Hz - 20kHz	90dB @ 1w/1m	8 ohms	12.4 oz (0.35 kg)	10.63" dia. (27 cm)	9.875" dia. (25 cm)	3.98" (10.1 cm)

Angled Woofer for Directional Sound - 15°, two-way, in-ceiling

Model	Description	Woofers	Tweeter	Recommended Power	Frequency Response	Sensitivity	Nominal Impedance	Magnet Structure	Overall Dimensions	Cut-out Dimensions	Mounting Depth
RSA-615	Performance Directional Shallow Depth 15° Angled two-way in-ceiling/in-wall	6.5" (16.51 cm) Polypropylene Cone	0.75" (1.9 cm) Pivoting PEI	5 - 80 watts	50Hz - 20kHz	88dB @ 1w/1m	8 ohms	Neo Magnet N40	9.13" dia. (23.19 cm)	8.375" dia. (21.27 cm)	3.7" (9.4 cm)
RSA-635	High Resolution Directional Shallow Depth 15° Angled two-way in-ceiling/in-wall	6.5" (16.51 cm) IMPP Cone	0.75" (1.9 cm) Pivoting Silk	10 - 100 watts	45Hz - 20kHz	88dB @ 1w/1m	8 ohms	Neo Magnet N40	9.13" dia. (23.19 cm)	8.375" dia. (21.27 cm)	3.7" (9.4 cm)
RSA-835	High Resolution Directional Shallow Depth 15° Angled two-way in-ceiling/in-wall	8" (20.32 cm) IMPP Cone	0.75" (1.9 cm) Pivoting Silk	10 - 100 watts	45Hz - 20kHz	88dB @ 1w/1m	8 ohms	Neo Magnet N40	10.63" dia. (27 cm)	9.875" dia. (25 cm)	3.78" (9.7 cm)

All Russound Acclaim speakers have a Limited Lifetime Warranty against defects in materials and workmanship. Proof of Purchase must accompany all claims. During the warranty period Russound will replace any defective part and correct any defect in workmanship without charge for either parts or labor.

Russound may replace returned speakers with a product of equal value and performance. In such cases, some modifications to the mounting may be necessary and are not Russound's responsibility.

For this warranty to apply, the unit must be installed and used according to its written instructions. If necessary, repairs must be performed by Russound. The unit must be returned to Russound at the owner's expense and with prior written permission. Accidental damage and shipping damage are not considered defects, nor is damage resulting from abuse or from servicing performed by an agency or person not specifically authorized in writing by Russound.

Russound products are sold only through authorized Dealers and Distributors to ensure that customers obtain proper support and service. Russound reserves the right to limit the warranty of products purchased from an unauthorized dealer or other source, including retailers, mail order sellers, and online sellers, to ninety (90) days from the date of purchase.

Damage to or destruction of components due to application of excessive power voids the warranty on those parts. In these cases, repairs will be made on the basis of the retail value of the parts and labor. To return for repairs, the unit must be shipped to Russound at the owner's expense, along with a note explaining the nature of service required. Be sure to pack the speaker(s) in a corrugated container with at least 3" (7.6 cm) of resilient material to protect the unit from damage in transit.

Before returning the unit for repair, call Russound at 603.659.5170 for a Return Authorization number. Write this number on the shipping label and ship to:

Russound
ATTN: Service
1 Forbes Road
Newmarket, NH 03857

This Warranty Does Not Cover:

- Damage caused by abuse, accident, misuse, negligence, or improper operation (installation).
- Products that have been altered or modified.
- Any product whose identifying number or decal, serial #, etc. has been altered, defaced or removed.
- Normal wear and maintenance.

Due to our continual efforts to improve product quality as new technology and techniques become available, Russound/FMP, Inc. reserves the right to revise speaker systems specifications without notice.

Troubleshooting Guide

Before returning your Russound speakers for service, try these simple remedies first.

No sound from either speaker:

- Incorrect source selected on receiver or preamplifier.
- Mute button pressed on receiver.
- Wrong speaker output selected; many receivers have an "A" and "B" speaker switch. Make sure it is in the correct position.
- In-wall Volume control not turned up or wired incorrectly.
- If using a speaker selector, room/station not turned on or improperly connected.

No sound from one speaker:

- Unsecured connection at either the speaker or amplifier - double-check all connections.
- Balance control turned all the way left or right - return it to center.
- Bad connecting cable between sound source and amplifier - try a new cable.
- Check for stray wire strands crossing the speaker terminals.
- Defective speaker - contact your Russound dealer or call Russound Tech Support at 603.659.5170.
- Any other problems not listed, discuss with your dealer or call Russound.



Acclaim™ Speakers

With Magnetic Edgeless Grilles

Installation Manual

©2015 Russound. All rights reserved.
All trademarks are the property of their respective owners.
Specifications are subject to change without notice.

Russound, Inc.
1 Forbes Road, Newmarket, NH 03857
tel 603.659.5170 • fax 603.659.5388
email: tech@russound.com www.russound.com

28-1373 04.14.15