

# 18Gbps HDBaseT Extender (70m) with ARC



## User Manual

VER 1.0

# Thank you for purchasing this product

For optimum performance and safety, please read these instructions carefully before connecting, operating or adjusting this product. Please keep this manual for future reference.

## Surge protection device recommended

This product contains sensitive electrical components that may be damaged by electrical spikes, surges, electric shock, lighting strikes, etc. Use of surge protection systems is highly recommended in order to protect and extend the life of your equipment.

## Table of Contents

1. Introduction.....	1
2. Features.....	1
3. Package Contents.....	2
4. Specifications.....	2
5. Operation Controls and Functions.....	4
5.1 Transmitter Panel.....	4
5.2 Receiver Panel.....	5
5.3 IR Pin Definition.....	7
6. Application Example.....	8

## 1. Introduction

This 18Gbps HDBaseT Extender can extend HDMI signal, bi-directional IR control signal, ARC signal and RS-232 control signal to a distance up to 70m / 230ft via a single CAT5e/6 cable. This product converts HDMI signal to standard HDBaseT signal and transmits it through LAN cable. It can easily control signal source device or display device from the remote end through bi-directional IR signal pass-through function. Video resolution up to 4K2K @60Hz. It supports ARC and POC function.

The extender can be widely used in other fields such as video conference system, multimedia signal broadcasting, HDMI signal extension, etc.

## 2. Features

- ☆ HDMI2.0b and HDCP 2.2 compliant
- ☆ Support 18Gbps video bandwidth
- ☆ Support video resolution up to 4K2K@60Hz RGB/YCBCR 4:4:4
- ☆ The transmission distance can be extended up to 70m / 230ft via a single CAT5e/6 cable
- ☆ Support bi-directional IR and RS-232 control signal pass-through
- ☆ Support ARC function, audio formats support Dolby 5.1, DTS 5.1, PCM2.0, etc.
- ☆ Advanced EDID management
- ☆ Support POC (Power over Cable) function
- ☆ Compact design for easy and flexible installation

### 3. Package Contents

- ① 1 x 18Gbps HDBaseT Extender (Transmitter)
- ② 1 x 18Gbps HDBaseT Extender (Receiver)
- ③ 1 x IR Blaster cable (1.5 meters)
- ④ 1 x IR Wideband Receiver cable (1.5 meters)
- ⑤ 2 x 3pin-3.81mm Phoenix Connectors (male)
- ⑥ 4 x Mounting Ears
- ⑦ 8 x Machine Screws
- ⑧ 1 x 24V/1A Locking Power Adapter
- ⑨ 1x User Manual

### 4. Specifications

Technical	
HDMI Compliance	HDMI 2.0b
HDCP Compliance	HDCP 2.2
Video Bandwidth	18Gbps
Video Resolution	Up to 4K2K@60Hz RGB/YCBCR 4:4:4
IR Level	5Vp-p
IR Frequency	Wideband 20K-60KHz
Transmission Distance	70m via a single CAT5e/6 cable
Color Space	RGB, YCbCr 4:4:4, YCbCr 4:2:2
Color Depth	8-bit, 10-bit, 12-bit (1080P) 8-bit (4K60) 8-bit, 10-bit, 12-bit (4K24/30)
HDR	HDR, HDR10, HDR10+, Dolby Vision, HLG
Audio Formats	HDMI: LPCM 7.1CH, Dolby True HD, and DTS-HD Master Optical: Dolby 5.1, DTS 5.1, PCM 2.0

<b>Connection</b>	
Transmitter	Input: 1×HDMI IN [TypeA, 19-pin female] Output: 1×HDBT OUT [RJ45] 1×SPDIF OUT Control: 1×RS-232 [3pin-3.81mm Phoenix connector] 1×SERVICE [Micro-USB jack] 1×IR IN [3.5mm Stereo Mini-jack] 1×IR OUT [3.5mm Stereo Mini-jack]
Receiver	Input: 1×HDBT IN [RJ45] 1×SPDIF IN Output: 1×HDMI OUT [TypeA, 19-pin female] Control: 1×RS-232 [3pin-3.81mm Phoenix connector] 1×SERVICE [Micro-USB jack] 1×IR IN [3.5mm Stereo Mini-jack] 1×IR OUT [3.5mm Stereo Mini-jack]
<b>Mechanical</b>	
Housing	Metal Enclosure
Color	Black
Dimensions	Transmitter / Receiver:140mm (W)×65mm (D)×18mm (H)
Weight	Transmitter: 235 g, Receiver: 239 g
Power Supply	DC 24V/1A; Support bi-directional POC function
Power Consumption	9.6 W (max)
Operating Temperature	0°C ~ 40°C / 32°F ~ 104°F
Storage Temperature	-20°C ~ 60°C / -4°F ~ 140°F
Relative Humidity	20~90% RH (non-condensing)

## 5. Operation Controls and Functions

### 5.1 Transmitter Panel

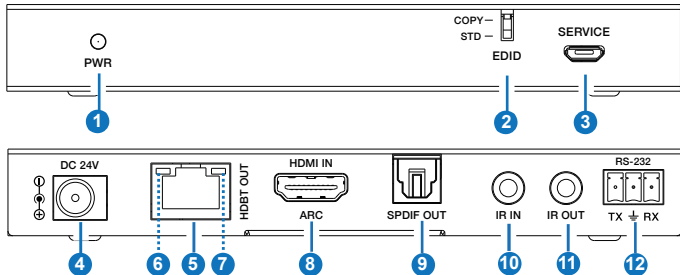

No.	Name	Function Description
1	Power LED	The red LED is on when the Transmitter is powered on.
2	EDID DIP switch	Used for audio EDID setting (dial to COPY by default). COPY: Copy the EDID of the HDMI OUT port of Receiver. STD: Default 1080P 2CH
3	SERVICE	Firmware update port.
4	DC 24V	DC 24V/1A power input port. <i>Note that the extender supports POC function, it means that either Transmitter or Receiver is connected to 24V/1A power supply, the other doesn't need power supply.</i>
5	HDBT OUT	RJ45 connector for connecting the HDBT IN port of the Receiver with CAT5e/6 cable.
6	Link Signal Indicator (Green)	<ul style="list-style-type: none"><li>• Illuminating: Transmitter and Receiver are in good connection status.</li><li>• Flashing: Transmitter and Receiver are in poor connection status.</li><li>• Dark: Transmitter and Receiver are not connected.</li></ul>
7	Data Signal Indicator (Orange)	<ul style="list-style-type: none"><li>• Illuminating: HDMI signal with HDCP.</li><li>• Flashing: HDMI signal without HDCP.</li><li>• Dark: No HDMI signal.</li></ul>
8	HDMI IN	HDMI signal input port. Connect to HDMI source device with HDMI cable.

No.	Name	Function Description
9	SPDIF OUT	Optical fiber audio signal output port.
10	IR IN	Connect to IR receiver cable, the IR receive signal will emit to the IR OUT port of the Receiver.
11	IR OUT	Connect to IR blaster cable, the IR emit signal is from the IR IN port of the Receiver.
12	RS-232	3-pin Phoenix connector for RS-232 command transmission. The RS-232 command will pass-through between the Transmitter and Receiver.

## 5.2 Receiver Panel

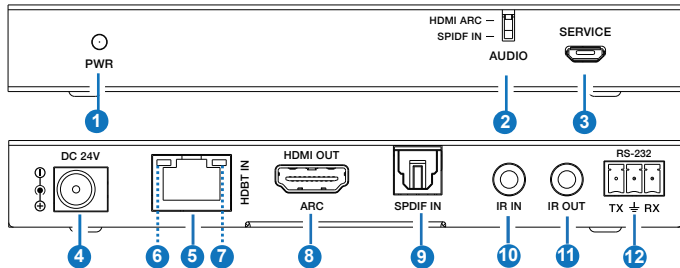

No.	Name	Function Description
1	Power LED	The red LED is on when the Transmitter is powered on.
2	AUDIO DIP switch	<ul style="list-style-type: none"> <li>When the HDMI IN port is connected to a signal source device with ARC function (e.g. Amplifier or Soundbar), the ARC function of the Extender is enable:  <b>Switcx to “HDMI ARC”</b> : the audio returned from the HDMI OUT port of Receiver will be output through the HDMI IN port and SPDIF OUT port of the Transmitter.</li> <li><b>Switcx to “SPDIF IN”</b> : the audio returned from the SPDIF IN port of Receiver will be output through the HDMI IN port and SPDIF OUT port of the Transmitter.</li> <li>When the HDMI IN port is connected to a common signal source device, the ARC function of the Extender is disable, the audio from the SPDIF IN port of the Receiver will be output through the SPDIF OUT port the Transmitter.</li> </ul>

No.	Name	Function Description
3	SERVICE	Firmware update port.
4	DC 24V	DC 24V/1A power input port. <i>Note that the extender supports POC function, it means that either Transmitter or Receiver is connected to 24V/1A power supply, the other doesn't need power supply.</i>
5	HDBT IN	RJ45 connector for connecting the HDBT OUT port of Transmitter with CAT6/6a cable.
6	Link Signal Indicator (Green)	<ul style="list-style-type: none"> <li>▪ Illuminating: Transmitter and Receiver are in good connection status.</li> <li>▪ Flashing: Transmitter and Receiver are in poor connection status.</li> <li>▪ Dark: Transmitter and Receiver are not connected.</li> </ul>
7	Data Signal Indicator (Orange)	<ul style="list-style-type: none"> <li>▪ Illuminate: HDMI signal with HDCP.</li> <li>▪ Flash: HDMI signal without HDCP.</li> <li>▪ Dark: No HDMI signal.</li> </ul>
8	HDMI OUT	HDMI signal output port. Connect to HDMI display devices with HDMI cable.
9	SPDIF IN	Optical fiber audio signal input port.
10	IR IN	Connect to the IR receiver cable. The IR signal will send to the IR OUT port of the Transmitter.
11	IR OUT	Connect to the IR blaster cable, the IR signal is from IR IN port of the Transmitter.
12	RS-232	3-pin Phoenix connector for RS-232 command transmission. The RS-232 command will pass-through between the Transmitter and Receiver.



## 5.3 IR Pin Definition

IR Receiver and Blaster pin's definition is as below:

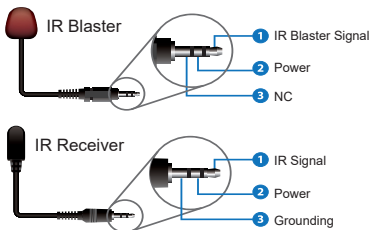

### Note:

When the angle between the IR receiver and the remote control is  $\pm 45^\circ$ , the transmission distance is 0-5 meters;

When the angle between the IR receiver and the remote control is  $\pm 90^\circ$ , the transmission distance is 0-8 meters.

## 6. Application Example

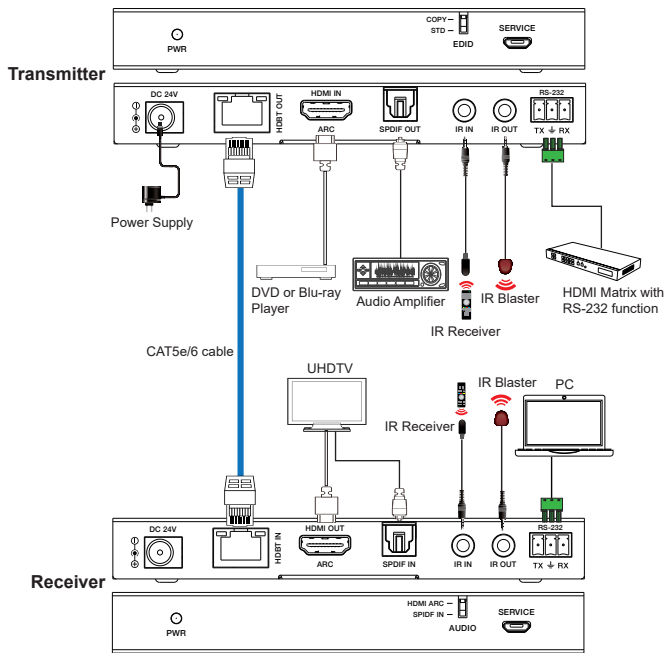

**HDMI™**  
HIGH-DEFINITION MULTIMEDIA INTERFACE

The terms HDMI and HDMI High-Definition Multimedia interface, and the HDMI Logo are trademarks or registered trademarks of HDMI Licensing LLC in the United States and other countries.